

Key: 181

Town of OAK BLUFFS - Fiscal Year 2021

10/27/2020 11:16 pm SEQ #: 180

LEGALS

CURRENT OWNER				PARCEL ID				LOCATION				
KIM LISA H CHUN EUNU 100 BARROW ST. APT 7B NEW YORK, NY 10014				3-15-0				7 ARLINGTON AV				
TRANSFER HISTORY				DOS	T	SALE PRICE	BK-PG (Cert)					
KIM LISA H				09/23/2011	F	1,200,000	1255-146					
KIM LISA H				09/23/2011	O	1,200,000	71-133					
FREIDRICH PAULINE E. ET				03/21/2000	A		(46096)					
CD	T	AC/SF/UN	Ngh	Inf1	Inf2	ADJ BASE	SAF	Inf3	Lpi	VC	CREDIT AMT	ADJ VALUE
100	S	25,700	090	1.04	100	1,068,249	2.17	NA	1.00	L09	4.55	1,365,260

CLASS	CLASS%	DESCRIPTION			BN ID	BN	CARD	
1010	100	SINGLE FAMILY				1	1 of 1	
PMT NO	PMT DT	TY	DESC	AMOUNT	INSP	BY	1st	%
XP849	11/03/2014	11	Window Rplc		01/07/2016	WP	100	100
		55	Measur/New U		10/18/2012	WP	0	0
		3	Renovations		10/18/2012		0	100
XP295	12/15/2011	51	Measur+1/Visi		09/27/2011	SL	0	0
		60	Field Review		05/18/2011	DM	0	0

LAND

TOTAL	25,700 SF	ZONING	FRNT	0	ASSESSED	CURRENT	PREVIOUS
Ngh	0090	N O T E Land: LOC			LAND	1,365,300	1,300,300
Inf1	100% GOOD		BUILDING	322,900	299,700		
Inf2	1		DETACHED	7,400	7,400		
			OTHER	0	0		
			<b>TOTAL</b>		<b>1,695,600</b>	<b>1,607,400</b>	

DETACHED

TY	QUAL	COND	DIM/NOTE	YB	UNITS	ADJ PRICE	RCNLD
DGF	A	1.00	50 0.50	1988	420	35.00	7,400

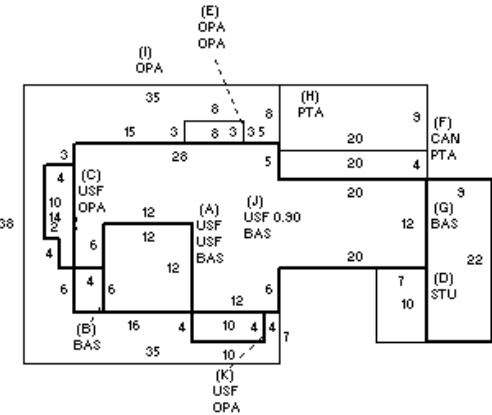

BUILDING

BUILDING	CD	ADJ	DESC	MEASURE
MODEL	1		RESIDENTIAL	LIST REVIEW
STYLE	7	1.71	OLD STYLE [100%]	
QUALITY	G-	1.26	MINUS GOOD [100%]	
FRAME	99	1.00	N/A [100%]	

BLDG COMMENTS

LOADING

YEAR BLT	1919	SIZE ADJ	1.000	ELEMENT	CD	DESCRIPTION	ADJ	S	BAT	T	DESCRIPTION	UNITS	YB	ADJ PRICE	RCN	TOTAL RCN	424,810		
NET AREA	2,102	DETAIL ADJ	1.513	FOUNDATION	99	N/A	1.00	+	BAS	L	BAS AREA	1,082	1919	173.46	187,689	CONDITION ELEM	CD		
\$NLA(RCN)	\$202	OVERALL	1.000	EXT. COVER	1	WOOD SHINGLE	1.00	+	USF	L	UP-STRY FIN	1,020	1919	173.46	176,934	EXTERIOR			
				ROOF SHAPE	1	GABLE	1.00	+	OPA	N	OPEN PORCH	710		36.52	25,928	INTERIOR			
				ROOF COVER	1	ASPH/CMP SHIN	1.00	D	STU	N	STORAGE UNF	70		91.30	6,391	KITCHEN			
				FLOOR COVER	1	HARDWOOD	1.00	+	PTA	N	PATIO/STOOP	260		20.00	5,200	BATHS			
				INT. FINISH	9	AVG+WALLBOARD	0.97	F	CAN	N	CANOPY	80		36.53	2,922	HEAT			
				HEATING/COOL	13	NONE	0.94	F21	O	FPL 2S 1OP	1		5,600.00	5,600	ELECT				
				FUEL SOURCE	5	WOOD	0.98	MST	O	MASONRY STACK	1		1,200.00	1,200					
									ODS	O	OUT DOOR SHWR-A	1		1,600.00	1,600				
CAPACITY		UNITS	ADJ															EFF.YR/AGE	1993 / 24
STORIES	3	1.00																COND	24 24 %
ROOMS	0	1.00																FUNC	0
BEDROOMS	4	1.00																ECON	0
FULL BATHS	3	\$11,346																DEPR	24 % GD 76
1/2 BATHS	0	1.00																RCNLD	\$322,900
FIXTURES	0	1.00																	
UNITS	1	1.00																	