

3 SECTION
3/8" = 1'-0"

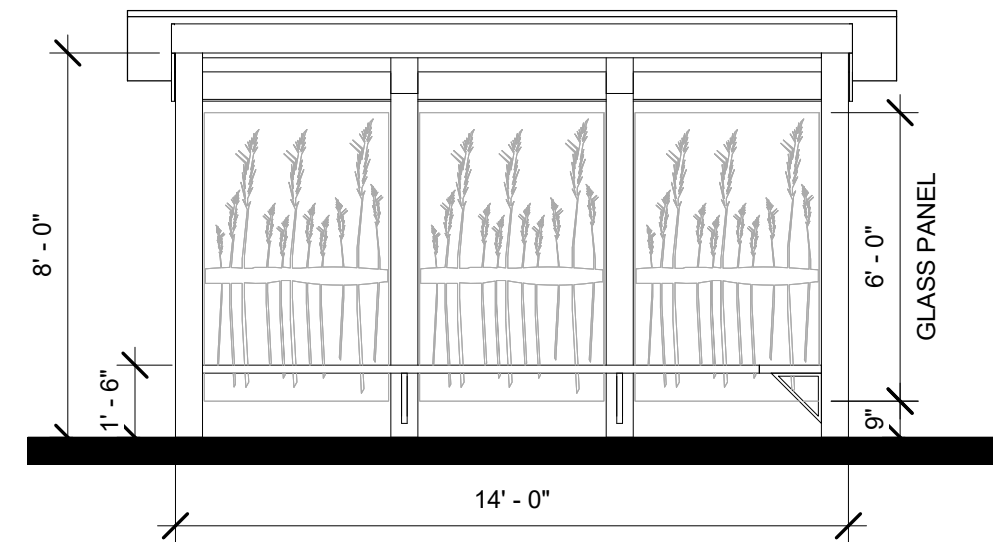

1 FRONT ELEVATION
1/4" = 1'-0"



4 PERSPECTIVE
NTS

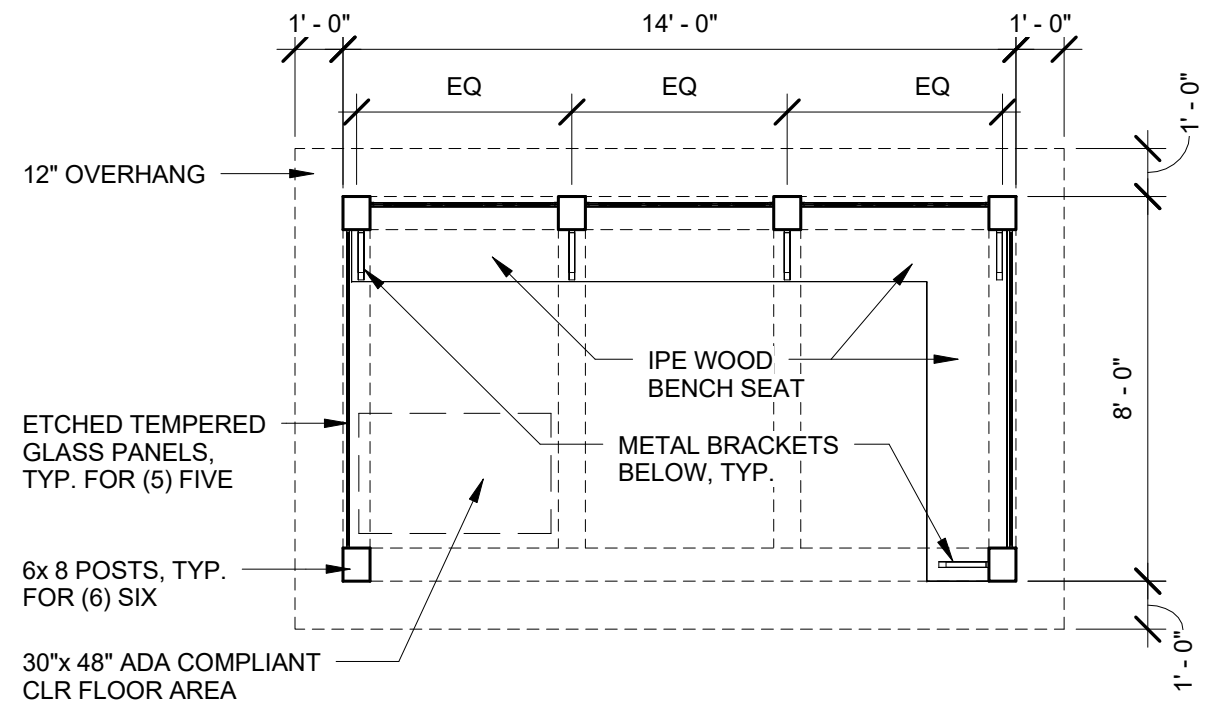

2 SHELTER FLOOR PLAN
1/4" = 1'-0"

UPPER MAIN STREET - PROPOSED BUS SHELTER

**Specification Sheet
6' Manchester Bench**

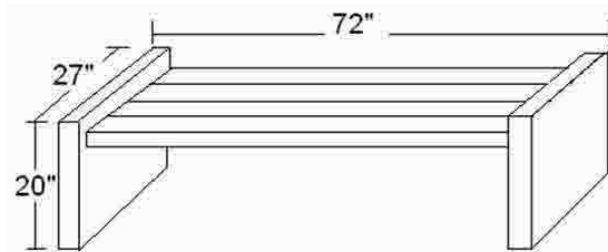

Specifications:

- Dimensions: 72" x 27" x 20"
- Weight: 400 lbs
- Materials: Steel reinforced concrete legs, Douglas Fir slats for seat
- Leg color options: Natural, Terra Cotta, Brown, Charcoal, or custom
- Leg finish options: Natural, Light Sandblast, Medium Sandblast, or Heavy Sandblast
- Wood color options: Natural, Forest Green, Cocoa, or custom stain
- Warranty: One year warranty against manufacturer's defects

3350 NW BOCA RATON BLVD., SUITE B2 • BOCA RATON, FL • 33431
PHONE: 561.620.7878 • FAX: 561.620.8668

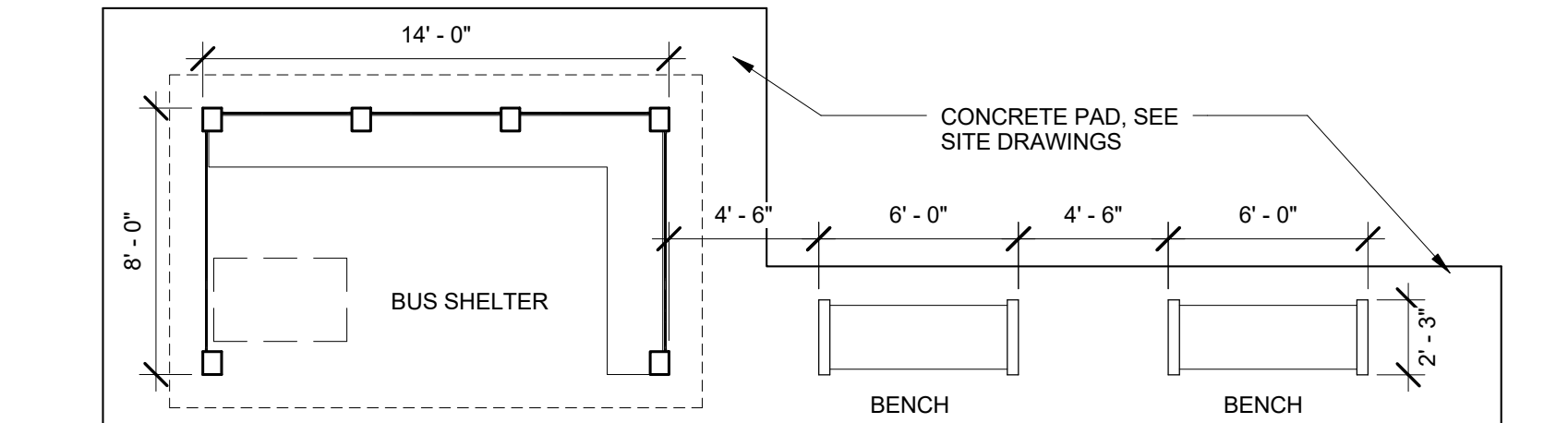

① PROPOSED BUS STOP SEATING
3/16" = 1'-0"