

100 YEAR FLOOD ELEVATION = 13.0 (VE ZONE) (SCALED FROM F.E.M.A. F.I.R.M. MAP REVISED JULY 20, 2016)

100 YEAR FLOOD ELEVATION = 12.0 (VE ZONE) (SCALED FROM F.E.M.A. F.I.R.M. MAP REVISED JULY 20, 2016)

100 YEAR FLOOD ELEVATION = 10.0 (AE ZONE) (SCALED FROM F.E.M.A. F.I.R.M. MAP REVISED JULY 20, 2016)

NOTES:

1. LOT AREA: 28,274± S.F.
2. DATUM: NAVD88.
3. TOP OF RETAINING WALL MUST NOT EXCEED 30" IN HEIGHT. MINOR FILLING ON ADJACENT PROPERTIES IS REQUIRED.

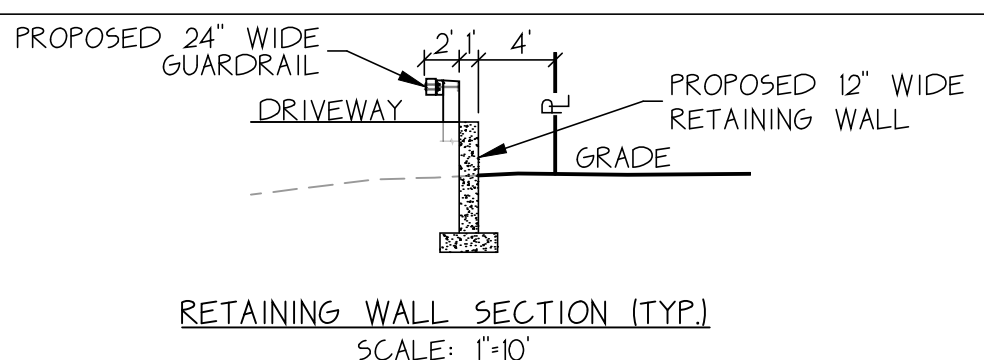

*Proposed Site Plan
in
Tisbury, Massachusetts
Assessor Parcel 9-B-18.1
69 Beach Road
prepared for
Vineyard Wind 1 LLC
Scale 1"=30' April 15, 2022*

**Sourati Engineering
Group LLC**

P.O. Box 4458
107 Beach Road, Suite 202
Vineyard Haven, MA 02568
Phone (508) 693-9933 Fax (508) 693-4933